



# Operator's Manual

# *Auto-Darkening Helmet*



## TABLE OF CONTENTS

Page

SAFETY WARNINGS – READ BEFORE USING	1
HELMET INFORMATION, SPECIFICATIONS	2
OPERATING INSTRUCTIONS	3
CARTRIDGE OPERATIONS/FEATURES	3
SHADE GUIDE SETTINGS	4
HELMET CARE AND MAINTENANCE	5
TROUBLESHOOTING	6
PARTS LISTS, WARRANTY INFORMATION	7

## GRAPHICS MAY VARY

### Save for future reference

Date Purchased

Code: (ex: 10859)

Serial: (ex: U1060512345)

2345 Murphy Blvd. • Gainesville, GA 30504  
Phone: +1.866.236.0044 • [www.lincolnelectric.com](http://www.lincolnelectric.com)

**IM10455** | Issue Date Oct-17

© Lincoln Global, Inc. All Rights Reserved.

## SAFETY WARNINGS – READ BEFORE USING



### WARNING

#### ARC Rays can injure eyes and burn skin

- Before welding, always inspect helmet and filter lens to be sure they are fitted properly, in good condition and not damaged.
- Check to see that the clear lens is clean and securely attached to the helmet.
- Always wear safety glasses or goggles under the welding helmet and protective clothing to protect your skin from radiation, burns and spatter.
- Ensure that optical radiation from other welder's arcs in the immediate area does not enter in from behind the helmet and auto-darkening filter.



**Note:** Auto-darkening filters in Lincoln helmets are designed to protect the user against harmful ultra-violet and infrared rays both in the dark and light states. No matter what shade the filter is set to, the UV/IR protection is always present.

#### FUMES AND GASES can be dangerous to your health.

- Keep your head out of fumes.
- Use enough ventilation or exhaust at the arc or both to keep fumes and gases from your breathing zone and general area.
- When welding with electrodes which require special ventilation such as stainless or hard facing (see instructions on container or MSDS) or on lead or cadmium plated steel and other metals or coatings which produce highly toxic fumes, keep exposure as low as possible and within applicable OSHA PEL and ACGIH TLV limits using local exhaust or mechanical ventilation. In confined spaces or in some circumstances, outdoors, a respirator may be required. Additional precautions are also required when welding on galvanized steel.



Refer to <http://www.lincolnelectric.com/safety>  
for additional safety information.

## HELMET INFORMATION

This Auto-Darkening Welding Helmet will automatically change from a light state (shade 4) to a dark state (Shade 9-13) when arc welding starts.

The filter automatically returns to a light state when the arc stops.  
Shade control adjustments can be made while welding.

Match your welding application to the shade indicated on the shade chart. (See Page 4)

- Operating temperature: 23°F ~ 131°F (-5°C ~ 55°C).
- Do not use or open the auto-darkening filter if damaged by shock, vibration or pressure.
- Keep the sensors and solar cell clean. Clean the filter cartridge using a soapy water solution and soft cloth which should be damp but not saturated.

This Auto-Darkening Welding Helmet is designed for use with GMAW, GTAW, MMAW, SMAW, FCAW welding, or Plasma Arc and air carbon arc cutting.

The cartridge provides protection from harmful UV and IR radiation, in both dark and light states.

The cartridge contains two sensors to detect the light from the welding arc, resulting in the lens darkening to a selected welding shade.

- Do not use solvents or abrasive cleaning detergent.
- If cover lens is spattered or covered with dirt, it should be replaced immediately.
- Do not use the helmet without inside and outside cover lenses properly installed.

## SPECIFICATIONS

LCD Viewing Area	97 x 44mm (3.82 x 1.73in)
Cartridge size	110 x 90mm (4.33 x 3.54in)
UV/IR Protection	Up to Shade DIN 16 at all times
Arc Sensors	2
Light State Shade	DIN 4
Variable Welding Shades	DIN 9 to 13 and grind (if equipped)
Shade Control	External knob - full adjustment
Power Supply	Solar cells - no battery required
Power On/Off	Fully automatic
Light to Dark Switching Time	0.0001 sec (1/10,000 sec)
TIG Rating	≥10 amps
Operating Temperature	23°F ~ 131°F (-5°C ~ 55°C)
Storage Temperature	-4° ~ 158°F (-20°C ~ 70°C)
Total Weight	496g (17.5 Oz.)
Compliance <sup>(1)</sup>	ANSI Z87.1-2003, CE

<sup>(1)</sup> Headgear compliance with ANSI Z87.1 is without sweatband installed.

# OPERATING INSTRUCTIONS

## Headgear Adjustment

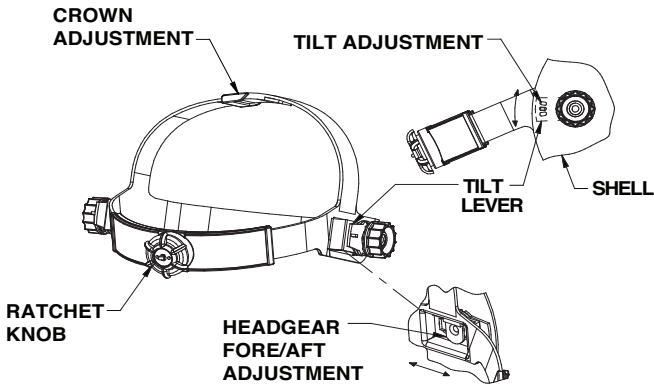

**Head Size Adjustment:** Headband tightness is adjusted by pushing in the ratchet knob and turning to adjust to desired comfort level. This knob is located at the back of the helmet. **HEAD GEAR CROWN ADJUSTMENT** is made by adjusting crown strap for vertical placement on the head and snapping the pin into the hole to lock securely in place.

**Tilt:** View angle is adjusted on both the left and right sides of helmet. Adjustment is made by loosening outside tension knobs of headgear and releasing tilt lever from its current location and moving it to another location. It is recommended this adjustment be completed one side at a time. Retighten tension knobs when finished. The view angle adjustment needs to be set the same for both tilt levers.

**Fore/Aft Adjustment:** Fore/Aft adjustment is the distance between the user's face and lens. To adjust, loosen the outside tension knobs to allow for headgear to be repositioned to a different location. This should be done one side at a time and both sides should be located the same for proper auto-darkening filter operation.

## CARTRIDGE OPERATION/FEATURES

### Variable Shade Control

The shade can be adjusted from shade 9 to 13 based upon welding process or application (refer to Shade selection chart on page 4). The variable shade control knob is mounted to shell for external adjustment. If equipped, **Grind** mode can be selected by rotating the shade control knob counterclockwise until an audible click is heard. **Grind mode is intended for grinding only and not for welding.**

### Solar Power

This helmet is powered by solar energy. As such, there is no battery that requires replacement.

**ALWAYS TEST TO BE SURE THE ADF CARTRIDGE IS CHARGED BEFORE WELDING.** The helmet can be placed in sunlight to charge. Do not store the helmet in a dark cabinet or other storage area for long periods. While welding, the arc also charges the ADF cartridge.

## SHADE GUIDE SETTINGS

GUIDE FOR SHADE NUMBERS				
OPERATION	ELECTRODE SIZE 1/32 in. (mm)	ARC CURRENT (A)	MINIMUM PROTECTIVE SHADE	SUGGESTED <sup>(1)</sup> SHADE NO. (COMFORT)
Shielded metal arc welding	Less than 3 (2.5) 3-5 (2.5-4) 5-8 (4-6.4) More than 8 (6.4)	Less than 60 60-160 160-250 250-550	7	–
			8	11
			10	12
			11	14
Gas metal arc welding and flux cored arc welding		Less than 60 60-160 160-250 250-500	7	–
			10	11
			10	12
			10	14
Gas tungsten arc welding		Less than 50 50-150 150-500	8	10
			8	12
			8	12
			10	14
Air carbon Arc cutting	(Light) (Heavy)	Less than 500 500-1000	10	12
			11	14
Plasma arc welding		Less than 20 20-100 100-400 400-800	6	6 to 8
			8	10
			10	12
			11	14
Plasma arc cutting	(Light) <sup>(2)</sup> (Medium) <sup>(2)</sup> (Heavy) <sup>(2)</sup>	Less than 300 300-400 400-800	8	9
			9	12
			10	14
Torch brazing		–	–	3 or 4
Torch soldering		–	–	2
Carbon arc welding		–	–	14
PLATE THICKNESS				
	in.	mm		
Gas welding Light Medium Heavy	Under 1/8	Under 3.2		4 or 5
	1/8 to 1/2	3.2 to 12.7		5 or 6
	Over 1/2	Over 12.7		6 or 8
Oxygen cutting Light Medium Heavy	Under 1	Under 25		3 or 4
	1 to 6	25 to 150		4 or 5
	Over 6	Over 150		5 or 6

<sup>(1)</sup> As a rule of thumb, start with a shade that is too dark, then go to a lighter shade which gives sufficient view of the weld zone without going below the minimum. In oxyfuel gas welding or cutting where the torch produces a high yellow light, it is desirable to use a filter lens that absorbs the yellow or sodium line the visible light of the (spectrum) operation.

<sup>(2)</sup> These values apply where the actual arc is clearly seen. Experience has shown that lighter filters may be used when the arc is hidden by the workpiece.

Data from ANSI Z49.1-2005

If your helmet does not include any one of the shades referenced above, it is recommended you use the next darker shade.

## HELMET CARE AND MAINTENANCE

**Replacing Front Cover Lens:** Replace the front cover lens if it is damaged – cracked, soiled or pitted. Place your finger or thumb into recess (C) at the bottom edge of the cover lens and flex the lens upwards until it releases from the edges marked A and B. (Refer to figure 1).

**Replace the Inside Cover Lens:** if it is damaged (cracked, soiled or pitted). Place your fingernail in recess above cartridge view window and flex lens upwards until it releases from edges of cartridge view window.

**Change the Shade Cartridge** (See figure 2)

**Fitting New Cartridge:** Take the new shade cartridge and pass the potentiometer cable under the wire loop before placing the cartridge into its retaining frame inside the helmet. Hinge down the wire loop and ensure the front edge of the loop (D) is properly retained under the retaining lugs (E) as shown in (figure 3).

Position the shade potentiometer to the inside of the helmet with the shaft protruding through the hole. Secure potentiometer to shell. On the outside of the helmet, push the shade control knob onto the shaft.

**Cleaning:** Clean helmet by wiping with a soft cloth. Clean cartridge surfaces regularly. Do not use strong cleaning solutions. Clean sensors and solar cells with soapy water solution and a clean cloth and wipe dry with a lint-free cloth. Do NOT submerge shade cartridge in water or other solution.

**Storage:** Store in a clean, dry location.

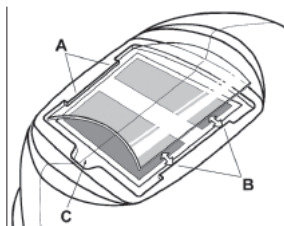

Figure 1

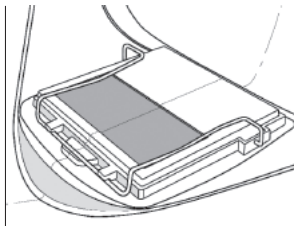

Figure 2

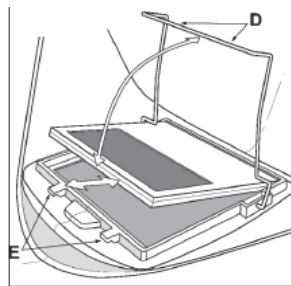



Figure 3

## TROUBLE SHOOTING GUIDE

Test your shade cartridge prior to welding by directing the front of the cartridge toward a bright source of light, then using your fingers rapidly cover and uncover the sensors. The cartridge should darken momentarily as the sensor is exposed. A torch striker can also be used.

PROBLEM	POSSIBLE CAUSE	SOLUTION
Difficult to see through filter.	Front cover lens dirty.	Clean or replace front cover lens.
	Cartridge dirty.	Clean the Auto-Darkening cartridge with soapy water solution and soft cloth.
Filter does not darken when arc is struck.	Front cover lens dirty.	Clean or replace front cover lens.
	Front cover lens is damaged.	Check for cracked or pitted front cover lens and replace as required.
	Sensors are blocked or Solar panel is blocked.	Make sure you are not blocking the sensors or solar panels with your arm or other obstacle while welding. Adjust your position so that the sensors can see the weld arc.

**⚠ WARNING**

	<b>ADF is cracked.</b>	<b>Cease (STOP) using this product if this problem exists. UV/IR protection may be compromised resulting in burns to the eyes and skin.</b>	
	<b>Weld spatter is damaging the filter.</b>	<b>Missing, damaged, broken, cracked or distorted front cover lens</b>	<b>Replace front cover lens as needed.</b>

## PARTS LIST

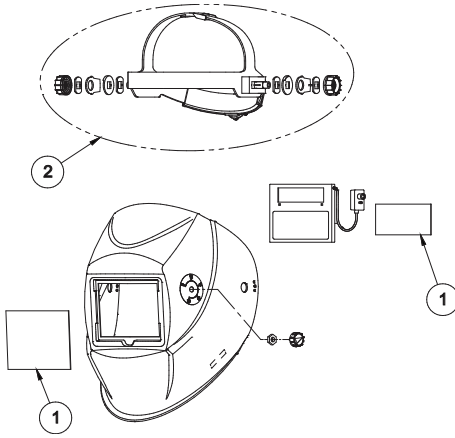

ITEM	DESCRIPTION	PART No.
1	Cover Lenses (2 inside, 2 outside)	KP3323-1
2	Headergear Assembly w/Sweatband	KP3324-1
3*	Sweatbands (2)	KP2854-1
4a*	1.5 Mag Cheater Lens	KH637
4b*	2.0 Mg. Cheater Lens	KH638
4c*	2.5 Mag. Cheater Lens	KH407

\* not illustrated

## WARRANTY INFORMATION

**WARRANTY INFORMATION:** These helmets are warranted for a period of one year. Please contact us at **1 (866) 236-0044** for any service or warranty questions.

### SPATTER DAMAGE IS NOT COVERED BY WARRANTY:

Do not use this product without the correct protective clear cover lenses installed properly on both sides of the Auto-Darkening Filter cartridge (ADF). The cover lenses supplied with this helmet are properly sized to work with this product and substitutions from other suppliers should be avoided

